

NOTE: SAFETY WIRE TENSION ARM BOLT (AN5H-13A) WITH .032" SAFETY WIRE.

REVISIONS

LTR.	DESCRIPTION	DATE	APR.
B	ADDED NOTE	6/06/05	SJK
C	CHANGED BOLT, WASHER & INSTALLATION INSTRUCTIONS	6/16/05	SJK
D	UPDATED PMA TAG	8/12/05	SJK
E	COMPANY NAME CHANGE	8/17/05	SJK
F	ADDED PART TAG DIM. & LOC.	9/09/05	SJK
G	ADJUSTED ANNOTATION	4/13/06	SJK

D
C
B
A

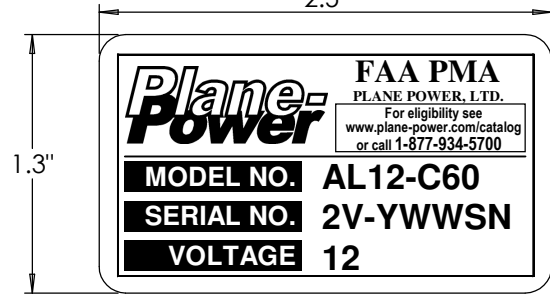
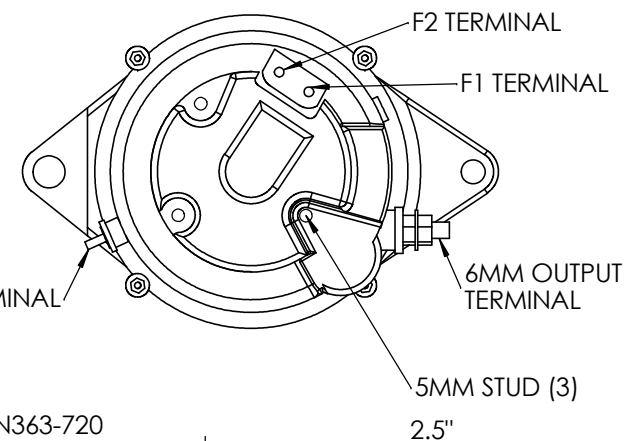
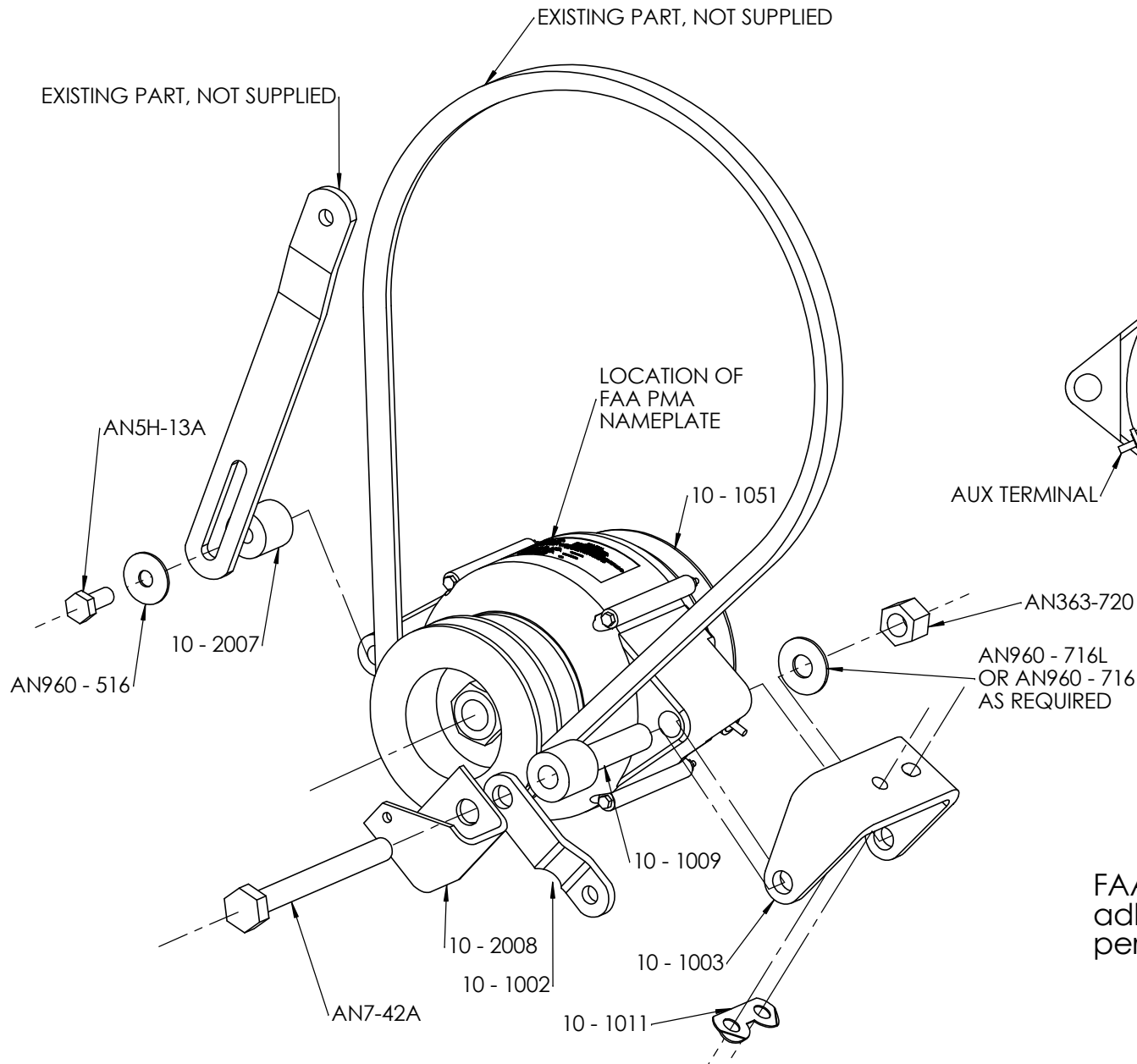

FAA PMA nameplate material to be adhesive backed Silver Polyester with permanent thermal print

INSTALLATION AND CONTINUED AIRWORTHINESS INSTRUCTIONS ON REVERSE SIDE

PLANE POWER, LTD.
GRANBURY, TEXAS

AL 12 - C60 INSTALLATION INSTRUCTIONS

DRAWN BY: **B. JOWERS** DATE: **2/15/05**

MATERIALS: DWG. NO. **10 - 2001** REV. **G**

8 7 6 5 4 3 2 1

8 7 6 5 4 3 2 1

Part No. 10-2001

Installation Instructions

1. Disconnect aircraft battery.
2. Install alternator per included drawing.
3. Refer to appropriate engine and airframe service manuals for belt tension and bolt torques.
4. Install battery wire with MS25171-2S terminal nipple on 6mm output terminal and torque to 50 in. lb.
5. Install ground wire to any of the three 5mm studs on rear of alternator and torque to 35 in. lb.
6. Install field wire with MS25171-1S terminal nipple to F1 terminal on rear of alternator and torque to 20 in. lb.
7. NOTE: F2 terminal to remain grounded with ground strap UNLESS aircraft voltage regulator is a type "A" regulator using a 2-wire field circuit, in this case remove and discard ground strap from F2 terminal and connect wiring from voltage regulator to F1 and F2 terminals, torque to 20 in. lb.
8. If aircraft is equipped with an "alternator out light" circuit, connect that wire to the AUX terminal and torque to 20 in. lbs. Other wise leave AUX terminal open.
9. Reconnect aircraft battery.
10. Start aircraft and check alternator output for proper operation.

Instructions For Continued Airworthiness

Annual / 100 hour inspections:

1. Remove drive belt and turn alternator rotor to check condition of bearings for abnormal noise or roughness.

5 year or 1,000 hour intervals:

1. Repeat: Annual / 100 hour inspection.
2. Remove field brush assembly and inspect brushes for excess wear. Replace brush assembly if brushes extend less than .250" from edge of brush holder case.

FOR CHEROKEE 140

(DRAWING SUPPLIED FOR FIELD FABRICATION)

REVISIONS

LTR.	DESCRIPTION	DATE	APR.
A	MATERIAL & VIEW CHANGED	3/21/05	SJK
B	COMPANY NAME CHANGE	8/17/05	SJK

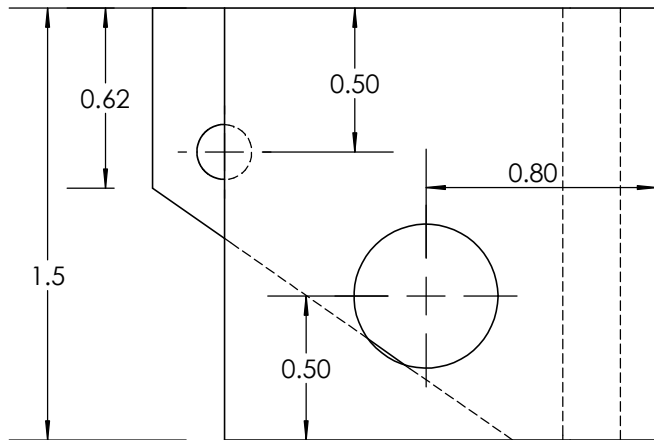
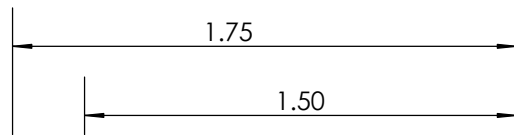
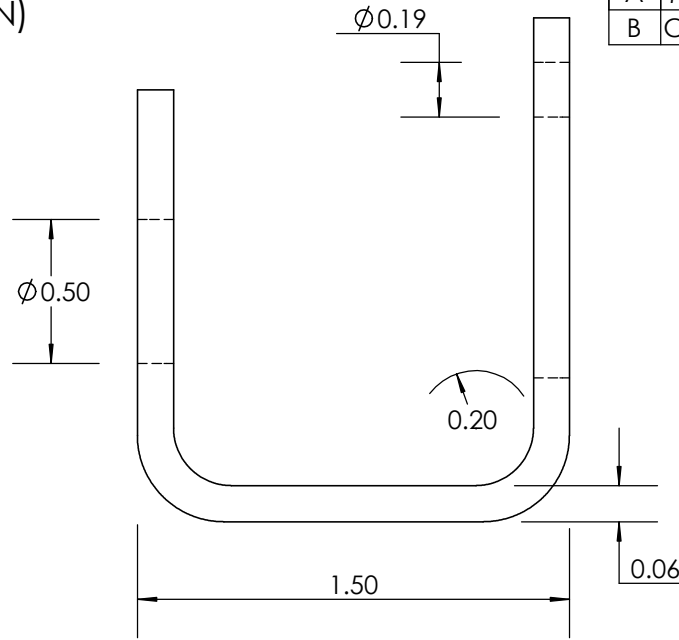

NOTE: BREAK ALL SHARP EDGES

PLANE POWER, LTD.

GRANBURY, TEXAS

BAFFLE SUPPORT BRACKET DRAWING

DRAWN BY: B. JOWERS		DATE: 2/15/05	
MATERIALS: COLD ROLLED STEEL		DWG. NO. 10 - 2008	REV. B

STANDARD TOLERANCES

ALL DIMENSIONS IN INCHES UNLESS SPECIFIED
 DECIMALS ± 0.03 ANGLES ± 1 DEGREE
 FRACTIONS ± 1/16 CONCENTRICITY 0.005 TIR