

# TAL24-70C

## INSTALLATION INSTRUCTIONS

### WIRING DIAGRAM

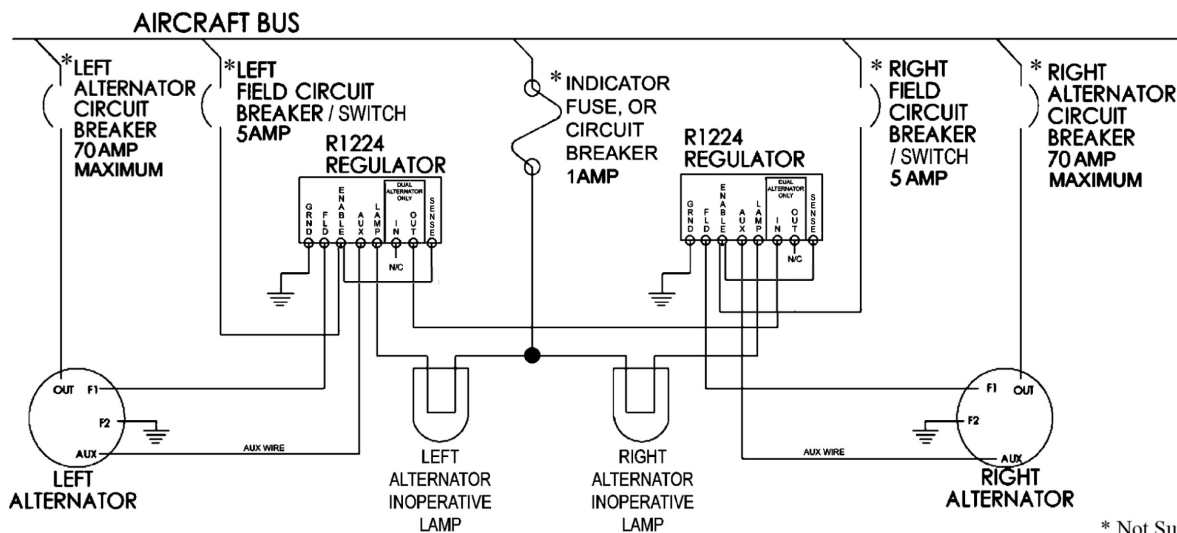

\* Not Supplied

**Drawing No.: 14-2001**  
**Belt Driven Alternator Conversion Installation Instructions**  
**For**  
**Model: TAL24-70C**  
**Multi- Engine Aircraft with Continental Engine**

Revision History			
Rev.	Date	By	Revisions
A	7/19/07	SJK	DELETED PAGE 5, 6-i UPDATED, PAGE 3 WIRING DIAGRAM UPDATED
B	5/23/08	SJK	DELETED 10-9099, ADDED 10-9099A, UPDATED PART 1 STEP 3, AND PAGE 3 INSTALLATION DIAGRAM
C	11/19/09	BRJ	REMOVED DUPLICATIONS, UPDATED DATA, ADDED ICA

Parts List:		
Qty	Part No.	Description
2	10-5050C	Alternator, 24 Volt, with 3.0" Diameter 3/8" V-Belt Pulley.
2	10-9099A	Mounting kit for Continental Engine.
2	R1224	Alternator Controller (Voltage Regulator) and data sheet 12-1001
1	ALP-1002	Placard, LEFT ALT INOP (Part of Drawing 14-1013)
1	ALP-1003	Placard, RIGHT ALT INOP (Part of Drawing 14-1013)
1	ALP-1004	Placard, LEFT ALT FIELD (Part of Drawing 14-1013)
1	ALP-1005	Placard, RIGHT ALT FIELD (Part of Drawing 14-1013)
1	14-2001	Installation Instructions (This document)
2	14-1011	Alternator Inoperative Lamp (28 Volt)

**READ AND THOROUGHLY UNDERSTAND ALL OF THE INSTALLATION INSTRUCTIONS BEFORE BEGINNING INSTALLATION OF THIS KIT.**

**NOTE: IF AIRCRAFT DOES NOT HAVE A CIRCUIT BREAKER OR CURRENT LIMITING DEVICE IN EACH GENERATOR'S OUTPUT AND REGULATOR'S INPUT CIRCUIT THEY MUST BE INSTALLED.**

### Part 1, Installation of Alternator and Regulator

1. Disconnect aircraft battery.
2. Remove Generators and voltage regulators.
3. Install Alternators per drawing on page 3. Tension the belts and torque the AN5H-7A adjusting bolts to 100 - 140 in/lb and safety wire with 0.032" diameter safety wire. Torque the AN7-43A mounting bolts to 450 - 500 in/lb or torque the AN6-41A mounting bolts to 160 - 190 in/lb.
4. **Ensure that internal jumper #1 and internal jumper #2 of each R1224 regulator are set for 28V operation** (See regulator instructions for location of jumpers).
5. If original output circuit breakers are rated at less than 70-amperes and you wish to be able to utilize the increased capacity of the alternators, remove the breakers and replace with suitable breakers up to 70amp maximum size. **Ensure wire size from alternator output terminal to output circuit breakers and from output circuit breakers to bus is rated for more than the size of breakers installed per AC43.13-1B.**  
**Note: If aircraft has been equipped with an Amp Meter, ensure that it is of adequate size to handle the increased output capability before increasing the output wire and breaker.**

## 6. Wire the system as follows:

- a. For regulator wiring instructions view the regulator installation instructions.
- b. Connect the GRND terminal of each regulator to the common aircraft ground.
- c. Leave the ground jumper installed on the F2 terminal of the alternator.
- d. Connect the existing generator output wires to each alternator's 6mm OUTPUT TERMINAL (or install a new wire in accordance with AC43.13-1B) using a MS25171-2S terminal nipple for insulation (Not Supplied). Torque to 50 in/lb.
- e. Use the original generator field wire or install a new wire, minimum 18AWG, from each alternator F1 terminal to the FLD terminal of the corresponding regulator. Torque the alternator's F1 terminal nut to 20 in/lb.
- f. Install, in view of the pilot, placard ALP-1004 (LEFT ALT FIELD) adjacent to the field switch for the left alternator and placard ALP-1005 (RIGHT ALT FIELD) adjacent to the switch for the right alternator.
- g. Ensure that each of the FIELD breakers are connected to the aircraft positive bus.
- h. If the aircraft has "Generator Inoperative" indicator lamps, they may be used in this step. If lamps are not currently installed or are not compatible use the supplied lamps P/n 14-1011 Alternator Inoperative Lamp (28 Volt) and install them in pilots clear field of view.
- i. Install, in view of the pilot, placard ALP-1002 (LEFT ALT INOP) adjacent to the lamp for the left alternator and placard ALP-1003 (RIGHT ALT INOP) adjacent to the lamp for the right alternator. Also run a new wire, minimum 18AWG, from the AUX terminal of each alternator to the AUX terminal of the corresponding regulator.

## 7. Adjust and Test the system:

- a. Set both FIELD switches to OFF.
- b. Turn on MASTER switch and start the engines. Ensure that both ALT INOP indicators are illuminated.
- c. Turn on the LEFT FIELD switch. Check proper charging indication. Check left ALT INOP indicator is off. Check aircraft maintenance manual for proper bus voltage (typically 28.0V  $\pm$  0.3V). Adjust the left (Master) regulator to the desired bus voltage at 1200 engine RPM.
- d. Turn off the LEFT FIELD switch and turn on the RIGHT FIELD switch. Check proper charging indication. Check right ALT INOP indicator is off. At 1200 engine RPM Adjust the right (Slave) regulator to the same bus voltage as left alternator.
- e. Turn on the LEFT FIELD switch.
- f. Check proper charging indication. Check bus voltage.
- g. Recheck and inspect the entire installation. Complete FAA form 337, make log book entry, update aircraft equipment list, and weight and balance.

Mounting Kit Parts List

10-9099A MOUNTING KIT COMPONENTS								
QTY	P/N	DESCRIPTION	QTY	P/N	DESCRIPTION	QTY	P/N	DESCRIPTION
1	10-9003	MOUNTING BRACKET	3	10-9005A	SPACER	2	MS35338-47	LOCK WASHER
1	10-9004A	TENSION ARM	1	10-9005B	SPACER	1	MS35338-45	LOCK WASHER
1	10-9006	SUPPORT BRACKET	1	AN6-41A	THRU BOLT	2	AN960-516	WASHER
1	10-1009	SPACER	1	AN7-43A	THRU BOLT	2	AN960-616	WASHER
1	10-3009	SPACER	1	AN5H-7A	BOLT	1	AN960-816L	WASHER
1	10-3010	SPACER	1	AN7-10A	BOLT	1	MS21045-6	NUT
1	10-3012	SPACER	1	MS20074-05-12	BOLT			

**FOR INSTALLATIONS WITH TCM BRACKET 628004  
(GENERATOR BRACKET MOUNTS BEHIND MOTOR MOUNT)**

\* NOTE: TCM# 539547-32.00 V-BELT REQUIRED (PURCHASE SEPERATELY)

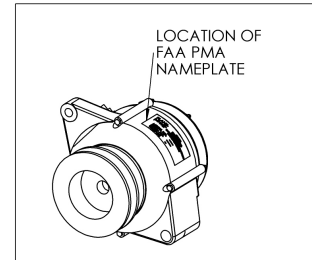
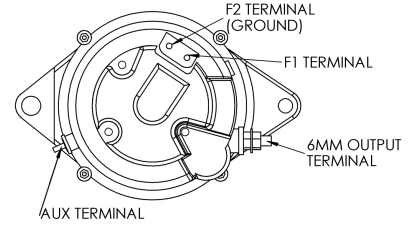
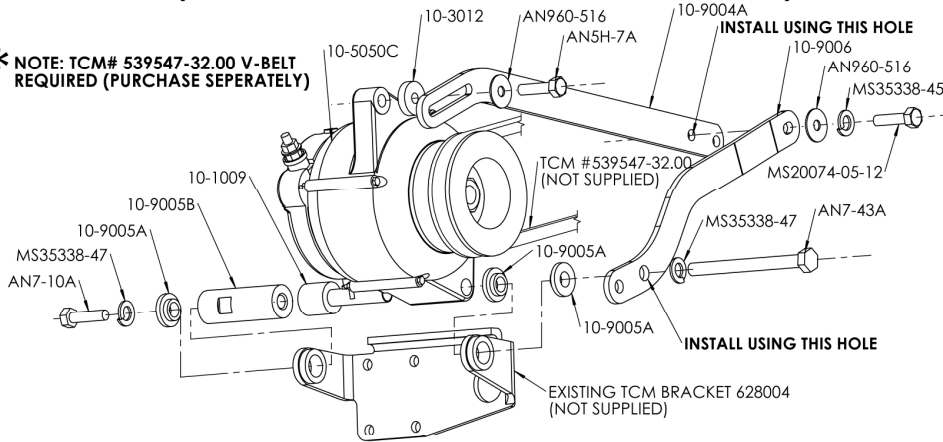

**FOR INSTALLATIONS WITHOUT TCM BRACKET 628004  
(EXISTING GENERATOR BRACKET MOUNTS ABOVE MOTOR MOUNT)**

\* NOTE: TCM# 539547-35.00 V-BELT REQUIRED (PURCHASE SEPERATELY)

FOR INSTALLATIONS ON CESSNA 310C - 310F WITH AIR INDUCTION BOX SUPPORT CESSNA# 0850604-6 ORDER PLANE-POWER SUPPORT KIT # 10-9007

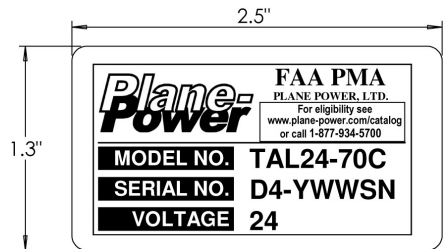
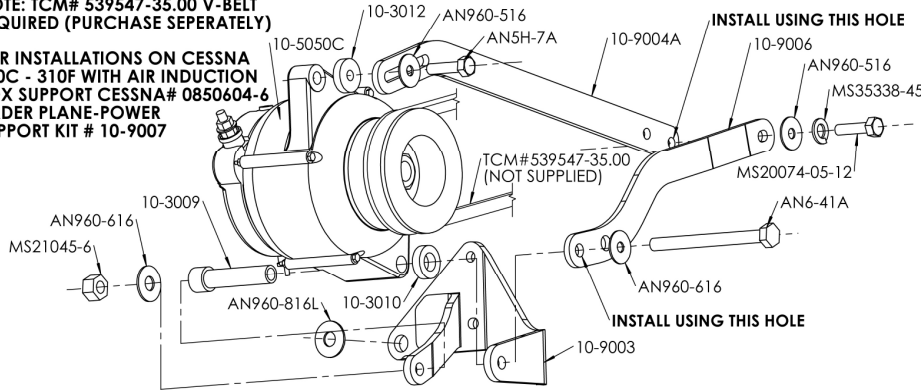

**Part 2, Preparation of FAA Form 337**

1. Installed Alternators in accordance with Supplemental Type Certificate No. SA10682SC. Updated Airplane Flight Manual with Plane-Power, Ltd. Airplane Flight Manual Supplement 002 (or later revision). Weight changed (compute weight and balance as necessary). Checked size of wire from Alternator output terminals to alternator circuit breakers and from Alternator circuit breakers to bus and size of Alternator circuit breakers with AC43.13-1B. (Note: use this statement as applicable. If wire and circuit breaker sizes are satisfactory, so state. If not satisfactory, state wire and/or circuit breaker size installed to conform with AC43.13-1B.)
2. Modified aircraft equipment list by removal of generators listed and adding Plane-Power Model TAL24-70C Alternator Kit.

**Weight and Balance**

Removed two generator installations:

Weight \_\_\_\_\_

Arm \_\_\_\_\_

(Refer to Aircraft Equipment List)

Removed two regulator installations:

Weight \_\_\_\_\_

Arm \_\_\_\_\_

(Refer to Aircraft Equipment List)

Installed TAL24-70C alternator kit consisting of:

(2) 10-5050C alternators 20.0lbs. wgt.

(2) 10-9099A mounting kits:  
With TCM Bracket 628004 2.2 lbs.

OR

With Plane-Power Bracket 10-9003 3.2 lbs.

(2) R1224 Voltage Regulators 0.6 lbs.

(1) ALP-1002 Placard Negligible

(1) ALP-1003 Placard Negligible

(1) ALP-1004 Placard Negligible

(1) ALP-1005 Placard Negligible

(2) 14-1011 Lamps Negligible

### **Part 3, Instructions for Continued Airworthiness**

#### PERIODIC MAINTENANCE:

1. It is recommended that the operation of the Plane Power, Ltd., TAL24-70C alternator be checked every 100 hour inspection or every annual inspection whichever ever comes first.
2. ANNUAL/100 HOUR INSPECTION:
  - a. Remove drive belt and turn alternator rotor to check condition of bearings for abnormal noise or roughness.
  - b. Each annual/100 hour inspection, the alternator and its associated wiring should be checked for secure electrical connections and physical connection to the airframe. The belt drive tension should be re-set to the aircraft manufacturer's specification.
3. 5 YEAR OR 1000 HOUR INSPECTION
  - a. Repeat the Annual/100 hour inspection.
  - b. Remove field brush assembly and inspect brushes for excess wear. Replace brush assembly if brushes extend less than 0.250 inches from edge of holder case.

#### AIRWORTHINESS LIMITATIONS

There are no mandatory replacement limits. There are no mandatory structural inspection intervals.

THE AIRWORTHINESS LIMITATIONS SECTION IS FAA APPROVED AND SPECIFIES MAINTENANCE REQUIRED UNDER SEC. 43.16 AND 91.403 OF THE FEDERAL AVIATION REGULATIONS UNLESS AN ALTERNATIVE PROGRAM HAS BEEN FAA APPROVED.