

Part Replacement Guide For Gear Driven Alternator

ER14-50

Manual Number: 11-9999

Rev: I.R. Date: 11/17/08

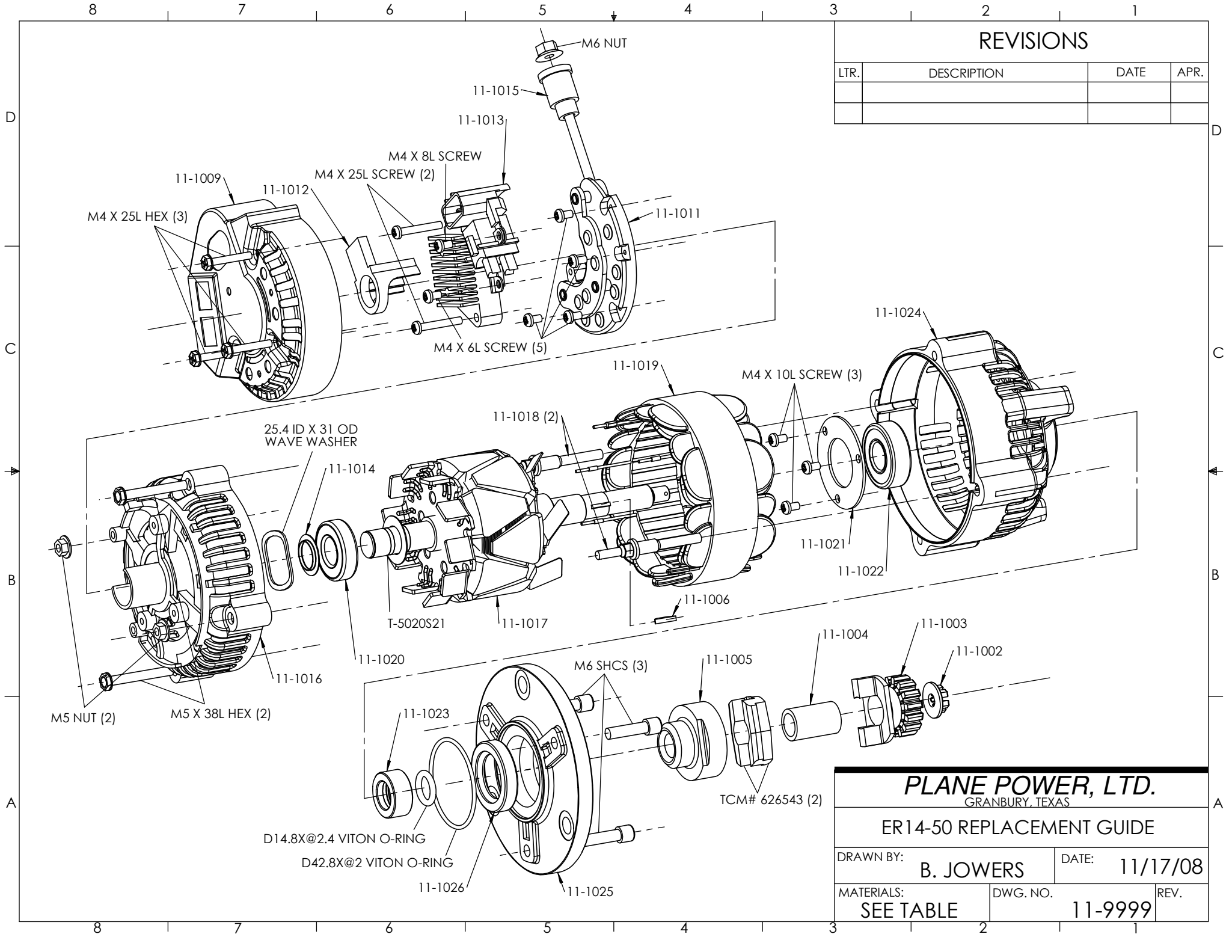

REVISIONS

LTR.	DESCRIPTION	DATE	APR.

PLANE POWER, LTD.
GRANBURY, TEXAS

ER14-50 REPLACEMENT GUIDE

DRAWN BY: B. JOWERS	DATE: 11/17/08
MATERIALS: SEE TABLE	DWG. NO. 11-9999
REV.	

11-9999 REPLACEMENT GUIDE: **GEAR DRIVEN**

Use the following guide and included drawing for disassembly, reassembly and replacement of parts in the Plane-Power ER14-50 Alternator.

The included drawing is to be used as a reference for any necessary procedures and a guide for assembly and disassembly as necessary for replacing any unsuitable parts or parts deemed no longer airworthy.

On reassembly torque all hardware according to the table below:

Size	Torque
M4X25L	16in. lbs.
M4X6L	16in. lbs.
M5X35L	35in. lbs.
M5 Nut	35in. lbs.
M6 Nut	35in. lbs.
M6 SHCS	85-90in. lbs.

If removal of Rear Housing is necessary 0.025” Safety wire must be removed before removing Rear Housing M5 Nuts and M5X35L Hex Bolts. On reassembly 0.025” Safety wire must be installed after Rear Housing M5 Nuts and M5X35L Bolts have been tightened to proper torque value.

After preliminary evaluation and determination of condition of alternator, necessary procedures must be taken to replace parts and clean alternator to conform to factory new standards.

After alternator is rebuilt to factory new standards test the alternator per applicable Process and Inspection Procedures.